

□FIAM

Re-Shoot 23-24

# Indice prodotti

Product index



**phantom**  
SPECCHIO / MIRROR  
04



**cristaline**  
TAVOLO / TABLE  
12



**agos**  
TAVOLO / TABLE  
28



**luxor**  
TAVOLO / TABLE  
36



**sahara**  
TAVOLO / TABLE  
48

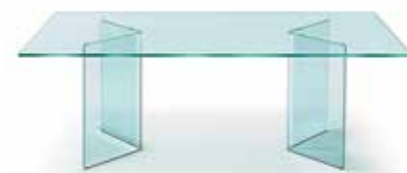

**corner**  
TAVOLO / TABLE  
56



**shell**  
TAVOLINO / COFFEE TABLE  
62



**rialto**  
TAVOLINO / COFFEE TABLE  
68



**toki**  
COMODINO / BEDSIDE TABLE  
72



**elementare**  
CONSOLLE / CONSOLE  
78



**charlotte**  
CONSOLLE / CONSOLE  
82



**palladio**  
VETRINA / SHOWCASE  
86



**inori**  
LIBRERIA / BOOKCASE  
92

**pelli / leathers**  
206

**tessuti / fabrics**  
207

**crediti / credits**  
212



Specchio da terra o da parete in vetro fuso da 6 mm retro argentato, specchio piano da 5 mm. Telaio posteriore in metallo verniciato. Possibilità di appendimento verticale od orizzontale.

Free-standing or hanging mirror in 6 mm high temperature melted glass, back-silvered. 5 mm flat mirror. Rear frame in painted metal. It can be hung horizontally or vertically.

Miroir appuyant au mur et accrochable en verre en fusion de 6 mm argenté, miroir plat de 5 mm. Cadre arrière en métal verni. Possibilité d'accrochage en horizontal ou en vertical.

Stand- bzw. Wandspiegel aus geschmolzenem Glas versilbert. Flacher Spiegel 5 mm stark. Hinterer Rahmen aus lackiertem Metall. Kann vertikal und horizontal aufgehängt werden.

# phantom

Helidon Xhixha & Dante O. Benini - Luca Gonzo



Specchio rettangolare da terra.  
Free-standing rectangular mirror.  
190 x 15 x 90 cm  
76 3/4" x 5 7/8" x 35 7/16"  
Divano Carrara, tavolino Coral Beach, tavolino Cannage.  
Carrara sofa, Coral Beach coffee table, Cannage coffee table.



Specchio rettangolare da terra.  
Free-standing rectangular mirror.

▲ 190 x 15 x 90 cm  
76 3/4" x 5 7/8" x 35 7/16"

◀ 198 x 18 x 98 cm  
78" x 7" x 38 9/16"

Tavolini Lakes, divano Carrara.  
Lakes coffee tables, Carrara sofa.

# phantom

Helidon Xhixha & Dante O. Benini - Luca Gonzo



Specchio da terra o da parete in vetro fuso da 6 mm retro argentato, specchio piano da 5 mm. Telaio posteriore in metallo verniciato. Possibilità di appendimento verticale od orizzontale.

Free-standing or hanging mirror in 6 mm high temperature melted glass, back-silvered. 5 mm flat mirror. Rear frame in painted metal. It can be hung horizontally or vertically.

Miroir appuyant au mur et accrochable en verre en fusion de 6 mm argenté, miroir plat de 5 mm. Cadre arrière en métal verni. Possibilité d'accrochage en horizontal ou en vertical.

Stand- bzw. Wandspiegel aus geschmolzenem Glas versilbert. Flacher Spiegel 5 mm stark. Hinterer Rahmen aus lackiertem Metall. Kann vertikal und horizontal aufgehängt werden.

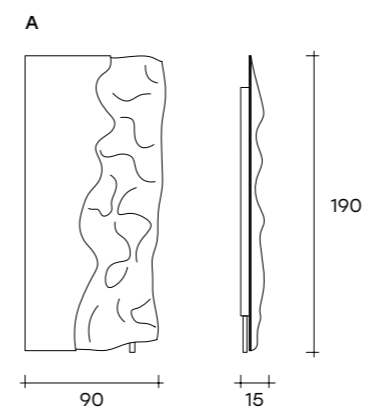

## POSSIBILI POSIZIONI / POSSIBLE POSITIONS

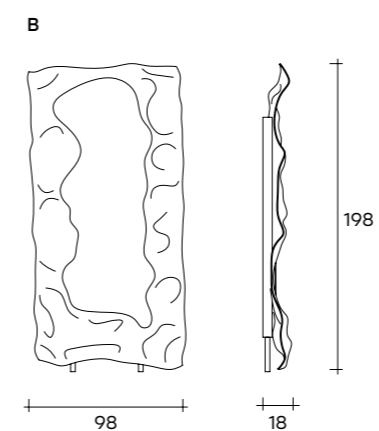
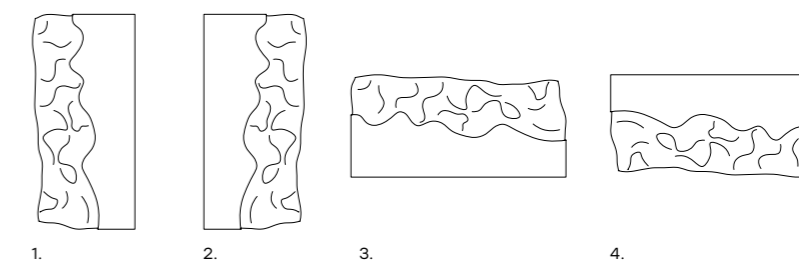

## POSSIBILI POSIZIONI / POSSIBLE POSITIONS

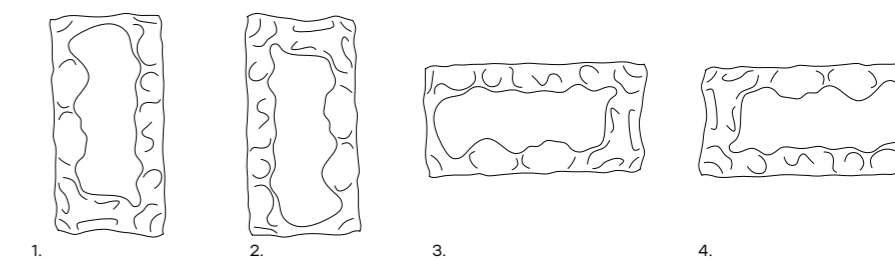

## Cornice in vetro fuso \_ Fused glass frame



Trasparente  
retroargentato  
Back-silvered glass



Bronzo  
retroargentato  
Back-silvered  
bronze glass



Fumè  
retroargentato  
Back-silvered  
smoked glass

## Mod. A

190 x 15 x 90 cm  
76 3/4" x 5 7/8" x 35 7/16"

## Mod. B

198 x 18 x 98 cm  
78" x 7" x 38 9/16"



Tavolo con piano in vetro extralight da 15 mm fuso a gran fuoco e temperato, disponibile trasparente o retroverniciato con tinte metallizzate. Base in metallo finitura Titanio opaco oppure Nichel Nero lucido. Il piano è disponibile anche in vetro extralight da 15 mm temperato, oppure in vetro bronzo o fumè da 16 mm stratificato e bisellato.

Table with top in 15 mm fused and tempered extralight glass, available transparent or back-lacquered with metallic paints. Metal base available in opaque Titanium or in Black Glossy Nickel finishes. The top is available also in 15 mm tempered extralight glass, or in 16 mm bronze or smoked glass, layered and bevelled.

Table avec plateau en verre extra light de 15 mm en fusion et trempé, disponible transparent ou vernie dessous avec des teintes métallisées. Base en métal, finition Titane opaque ou Nickel noir brillant. Le plateau est disponible aussi en verre extra light de 15 mm trempé ou en verre bronze ou fumé de 16 mm feuilleté et biseauté.

Tisch mit platte aus 15 mm geschmolzenem und gehärtetem extralight Glas, transparent oder unterlackiert mit metallischen Farben erhältlich. Untergestell aus Metall in den folgenden Farbvarianten: Matt Titan oder Glanz Schwarz Nickel. Die Platte ist in den folgenden Varianten erhältlich: - 15 mm extralight gehärtetes Glas oder 16 mm geschichtete Bronze- bzw Rauchglas.

**cristaline**  
Marcel Wanders







Base in metallo finitura nichel nero lucido  
 Piano in vetro extralight fuso.  
 Black Glossy Nickel finish metal base,  
 Fused extralight glass top.  
 300 x 110 x 75 cm  
 118 1/8" x 43 5/16" x 29 1/2"  
 Poltroncine Oscar, vetrine Aura, lampada Pearl.  
 Oscar chairs, Aura showcases, Pearl lamp.





Base in metallo finitura nichel nero lucido  
Piano in vetro extralight fuso.  
Black Glossy Nickel finish metal base,  
Fused extralight glass top.  
300 x 110 x 75 cm  
118 1/8" x 43 5/16" x 29 1/2"  
Sedie Oscar, specchio Silica.  
Oscar chairs, Silica mirror.



Base in metallo finitura Titanio opaco,  
Piano in vetro extralight liscio.  
Opaque Titanium finish metal base,  
Extralight flat glass top.  
300 x 110 x 75 cm  
118 1/8" x 43 5/16" x 29 1/2"  
Sedie Callas, vetrine Echo,  
lampada Pearl, libreria Inori.  
Callas chairs, Echo showcases,  
Pearl lamp, Inori bookcase.



Base in metallo finitura Titanio Opaco,  
Piano in vetro extralight fuso retroverniciato Marrone Brillante.  
Opaque Titanium finish metal base,  
Fused extralight glass top, Brilliant Brown back-painted.  
Libreria Inori.  
Inori bookcase.



Base in metallo finitura Titanio Opaco,  
Piano in vetro extralight fuso retroverniciato Marrone Brillante.  
Opaque Titanium finish metal base,  
Fused extralight glass top, Brilliant Brown back-painted.  
300 x 110 x 75 cm  
118 1/8" x 43 5/16" x 29 1/2"  
Sedie Callas, libreria Inori.  
Callas chairs, Inori bookcase.

# cristaline

Marcel Wanders



Tavolo con piano in vetro extralight da 15 mm fuso a gran fuoco e temperato, disponibile trasparente o retroverniciato con tinte metallizzate. Base in metallo finitura Titanio opaco oppure Nichel Nero lucido. Il piano è disponibile anche in vetro extralight da 15 mm temperato, oppure in vetro bronzo o fumè da 16 mm stratificato e bisellato.

Table with top in 15 mm fused and tempered extralight glass, available transparent or back-lacquered with metallic paints. Metal base available in opaque Titanium or in Black Glossy Nickel finishes. The top is available also in 15 mm tempered extralight glass, or in 16 mm bronze or smoked glass, layered and bevelled.

Table avec plateau en verre extra light de 15 mm en fusion et trempé, disponible transparent ou vernie dessous avec des teintes métallisées. Base en métal, finition Titane opaque ou Nickel noir brillant. Le plateau est disponible aussi en verre extra light de 15 mm trempé ou en verre bronze ou fumé de 16 mm feuilleté et biseauté.

Tisch mit platte aus 15 mm geschmolzenem und gehärtetem extralight Glas, transparent oder unterlackiert mit metallischen Farben erhältlich. Untergestell aus Metall in den folgenden Farbvarianten: Matt Titan oder Glanz Schwarz Nickel. Die Platte ist in den folgenden Varianten erhältlich: - 15 mm extralight gehärtetes Glas oder 16 mm geschichtete Bronze- bzw Rauchglas.

## Base in metallo \_ Metal base

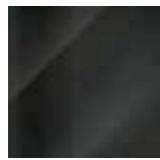

Nichel Nero Lucido  
Black Glossy Nickel



Titanio Opaco  
Opaque Titanium

## Piano in vetro liscio \_ Flat glass top



Vetro extralight  
Extralight glass



Vetro fumé  
Smoked glass



Vetro bronzo  
Bronze glass

## Piano in vetro fuso \_ Fused glass top



Vetro extralight  
Extralight glass



Vetro extralight  
retroverniciato  
Nero Brillante  
Back-painted  
extralight glass,  
Brilliant Black finish



Vetro extralight  
retroverniciato  
Marrone Brillante  
Back-painted  
extralight glass,  
Brilliant Brown finish

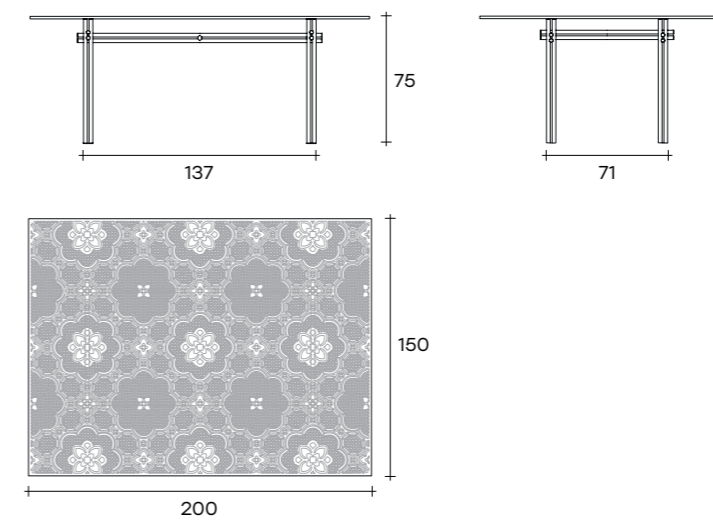
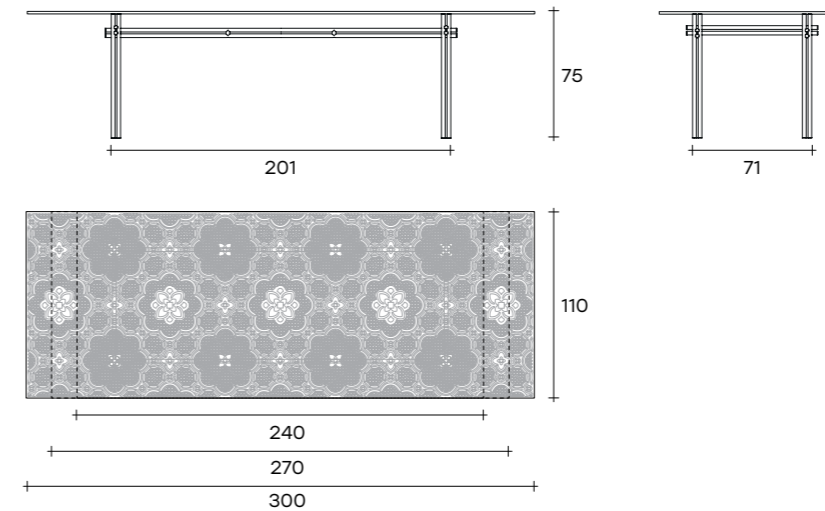

## PARTICOLARE BISELLATURA BEVEL DETAIL

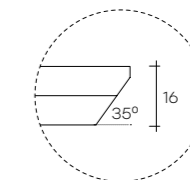

### rettangolare / rectangular

240 x 110 x 75 cm  
94 1/2" x 43 5/16" x 29 1/2"  
270 x 110 x 75 cm  
106 5/16" x 43 5/16" x 29 1/2"  
300 x 110 x 75 cm  
118 1/8" x 43 5/16" x 29 1/2"

### falso quadrato / false square

200 x 150 x 75 cm  
78 3/4" x 59" x 29 1/2"



Agos nasce dalla volontà di realizzare una collezione di tavoli caratterizzati da un design raffinato ed al contempo rassicurante. Per la base abbiamo immaginato un vero e proprio schema architettonico che collega i piedi della struttura creando un sistema di linee che intersecate fra loro danno vita ad un gioco prospettico davvero interessante. La struttura è in acciaio verniciato, collegata da traverse a sostenere i piani in vetro trasparente in varie forme.

Agos was born out of the willingness to create a collection of tables characterized by a polished yet reassuring design. For the base we imagined an out-and-out architectural scheme that connects the feet of the structure, creating a system of lines that intersect each other and result in a very interesting perspective play. The structure is made of painted steel, connected by crossbars to support the transparent glass tops in various shapes.

Agos est née du désir de créer une collection de tables caractérisées par un design raffiné mais rassurant. Pour la base, nous avons imaginé un véritable schéma architectural qui relie les pieds de la structure, en créant un système de lignes qui se croisent pour créer un jeu de perspective vraiment intéressant. La structure est en acier verni, reliée par des traverses pour soutenir les plateaux en verre transparent de différentes formes.

Agos ist aus dem Willen entstanden, eine Kollektion von Tischen zu schaffen, die sich durch ein raffiniertes und beruhigendes Design. Für die Basis haben wir uns ein regelrecht architektonisches Schema ausgedacht, das die Füße der Struktur miteinander verbindet und ein System von Linien schafft, die sich gegenseitig schneiden und ein sehr interessantes Perspektivespiel ergeben. Die Struktur besteht aus lackierendem Stahl, die durch Querbalken verbunden ist, der die transparente Glasfläche in verschiedenen Formen lagert.

**agos**

Ludovica + Roberto Palomba







Piano in vetro fuso retroverniciato,  
finitura Nero Brillante.  
Fused and back-painted glass top,  
Brilliant Black finish.

Base in metallo finitura Greige Metallizzato, piano in vetro bronzo.  
Metallic Greige finish metal base, bronze glass top.

ø160 x 75 cm  
ø63" x 29 1/2"

Sedie Callas, lampada Marry Me.  
Callas chairs, Marry Me lamp.





# agos

Ludovica + Roberto Palomba



Tavolo con base in metallo verniciato, finitura Grigio Lava o Greige Metallizzato. Piano in vetro extralight da 15 mm fuso a gran fuoco e temperato, disponibile trasparente o retroverniciato con tinte metallizzate. Il piano è disponibile anche in vetro extralight da 15 mm temperato, oppure in vetro bronzo o fumè da 16 mm stratificato e bisellato.

Table with painted metal base, in Lava Grey or Metallic Greige finish. Top made of 15 mm extralight, fused and tempered glass, available transparent or back-painted with metallic colours. The top is available also in 15 mm tempered extralight glass, or in 16 mm bronze or smoked glass, layered and bevelled.

Table avec piètement en métal verni, finition Gris Lave ou Greige métallisé. Plateau en verre en fusion et trempé finition extra light de 15 mm, disponible transparent ou verni dessous avec des teintes métallisées. Le plateau est disponible aussi en verre extra light de 15 mm trempé ou en verre bronze ou fumé de 16 mm feuilleté et biseauté.

Tisch mit Gestell aus lackiertem Metall in der Farbe Lava Grau oder Metallish Greige. Platte aus 15 mm extralight gehärtetes Glas in den folgenden Varianten erhältlich: - verschmolzen, transparent oder mit Metallfarben unterlackiert - extralight mit Facettenschliff oder mit 16 mm geschichtete Bronze- oder Rauchglasplatte.

## Base in metallo \_ Metal base



Grigio Lava  
Lava Grey



Greige Metallizzato  
Metallic Greige

## Piano in vetro liscio \_ Flat glass top



Vetro extralight  
Extralight glass



Vetro fumé  
Smoked glass



Vetro bronzo  
Bronze glass

## Piano in vetro fuso \_ Fused glass top



Vetro extralight  
Extralight glass

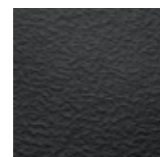

Vetro extralight  
retroverniciato  
Nero Brillante  
Back-painted  
extralight glass,  
Brilliant Black finish



Vetro extralight  
retroverniciato  
Marrone Brillante  
Back-painted  
extralight glass,  
Brilliant Brown finish

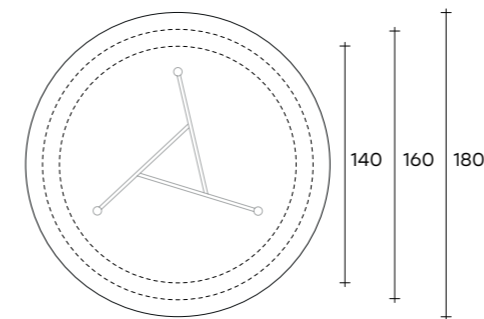
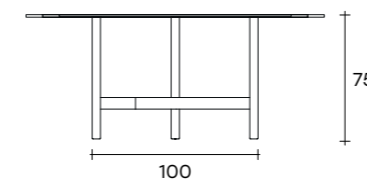
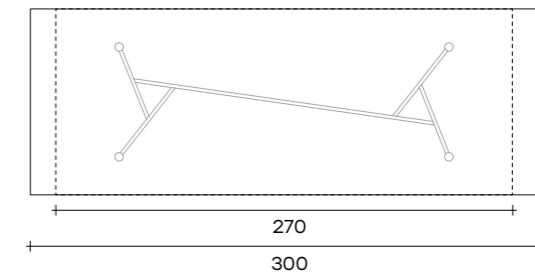
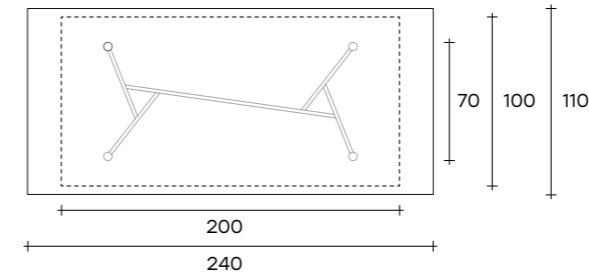
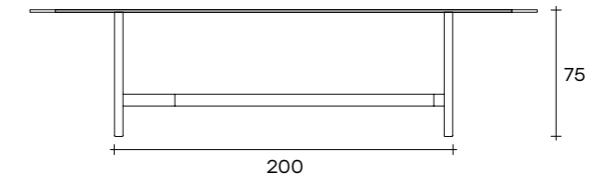
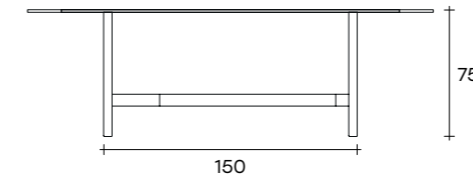

## PARTICOLARE BISELLATURA BEVEL DETAIL

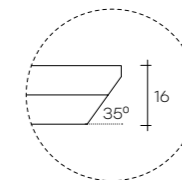

## rettangolare / rectangular

200 x 100 x 75 cm  
78 3/4" x 39 3/8" x 29 1/2"

240 x 110 x 75 cm  
94 1/2" x 43 5/16" x 29 1/2"

270 x 110 x 75 cm  
106 5/16" x 43 5/16" x 29 1/2"

300 x 110 x 75 cm  
118 1/8" x 43 5/16" x 29 1/2"

## tondo / round

ø 140 x 75 cm  
ø 55 1/8" x 29 1/2"

ø 160 x 75 cm  
ø 63" x 29 1/2"

ø 180 x 75 cm  
ø 70 7/8" x 29 1/2"

Tavolo con piano in vetro fumé o bronzo stratificato da 8+8 mm finitura filo lucido tondo, disponibile anche in vetro temperato trasparente o extralight. A seconda della misura e della configurazione desiderata base composta da 2, 3 o 4 cilindri (Ø 40 cm) in vetro da 10 mm, disponibile fumé, bronzo trasparente o extralight. Disponibile anche con piani a misura.

Dining table with layered glass top 8+8 mm-thick brilliant polished rim, in smoked or bronze glass also available in tempered glass, transparent or extralight. 10 mm-thick curved glass base, composed of 2, 3 or 4 cylinders (Ø 40 cm) depending upon the size and the shape requested. Bases are available in smoked glass, bronze glass, transparent glass or extralight glass. Custom size top available on request.

Table avec plateau en verre feulleté de 8+8 mm fumé ou bronze finition chant poli arrondi, ou en verre trempé transparent ou extralight. Base en verre cintré de 10 mm se composant de 2, 3 ou 4 cylindres (Ø 40 cm) dépendant de la mesure ou de la configuration désirée. Disponible en verre fumé, en verre bronze, en verre transparent ou en verre extralight. La table Luxor est également disponible avec le plateau sur mesure.

Tisch mit 8+8+ mm-starker Schichtglasplatte in Rauch- oder Bronze-Glas oder in transparentem bzw. extralight gehärtetem Glas. Untergestell bestehend aus 2, 3 bzw. 4 Zylindern (Durchmesser 40 cm) abhängig von den gewünschten Massen und Gestaltung, aus 10 mm-starkem gebogenem Glas, lieferbar in den Ausführungen Rauchglas, oder Bronzeglas, transparentes bzw. extralight Glas. Auch mit maßgefertigter Platte lieferbar.



Tavolo rettangolare in vetro fumè.  
Rectangular table in smoked glass.  
300 x 110 x 75 cm  
118 1/8" x 43 5/16" x 29 1/2"

Poltroncine Newton, specchio Caadre.  
Newton chairs, Caadre mirror.



*(photo p.38-39)*  
Tavolo rettangolare in vetro bronzo.  
Rectangular table in bronze glass.  
300 x 110 x 75 cm  
118 1/8" x 43 5/16" x 29 1/2"  
Poltroncine **Newton**, libreria **Remind**.  
**Newton** chairs, **Remind** bookcase.



Tavolo tondo in vetro bronzo.  
Round table in bronze glass.

ø 160 x 75 cm  
ø 63" x 29 1/2"

Poltroncine Oscar, libreria Inori.  
Oscar chairs, Inori bookcase.





# luxor

Rodolfo Dordoni



Tavolo con piano in vetro fumé o bronzo stratificato da 8+8 mm con bordo lucido tondo, disponibile anche in vetro temperato trasparente o extralight. Piani disponibili a misura. Base composta da 2, 3 o 4 cilindri (Ø 40 cm) in vetro da 10 mm, disponibile fumé, bronzo, trasparente o extralight.

Dining table with smoked or bronze 8+8 mm-thick layered glass top with polished round rim, also available in transparent or extralight tempered glass. Custom sized top available. 10 mm-thick curved glass base composed of 2, 3 or 4 cylinders (Ø 40 cm) available in smoked, bronze, transparent or extralight glass.

Table avec plateau en verre fumé ou bronze feuilleté 8+8 mm avec chant poli arrondi, également disponible en verre trempé transparent ou extra light. Plateaux disponibles sur mesure. Base composée de 2,3 ou 4 cylindres (Ø 40 cm) en verre de 10 mm, disponible en fumé, bronze, transparent ou extra light.

Eßtisch mit geschichteter Glasplatte 8+8 mm aus Rauch- oder Bronzeglas oder aus gehärtetem Glas, transparent oder extralight. Polierter runder Rand. Platte in Sondergröße erhältlich. 10 mm Stark gebogener Untergestell, bestehend aus 2, 3 oder 4 Zylindern (Ø 40 cm) lieferbar in den Ausführungen Rauchglas oder Bronzeglas oder transparentes bzw extralight Glas.

## PIANO RETTANGOLARE RECTANGULAR TOP

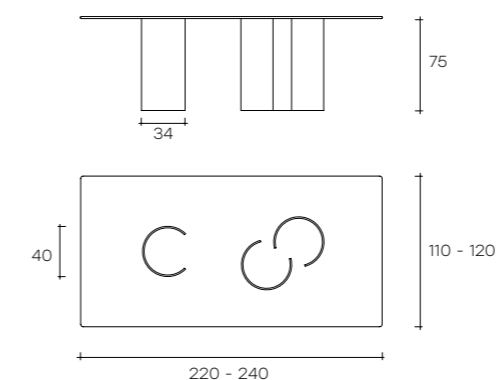

220 x 110 x 75 cm  
86 5/8" x 43 5/16" x 29 1/2"

240 x 120 x 75 cm  
94 1/2" x 47 1/4" x 29 1/2"

150 x 150 x 75 cm  
59 1/16" x 59 1/16" x 29 1/2"

## PIANO QUADRATO SQUARE TOP

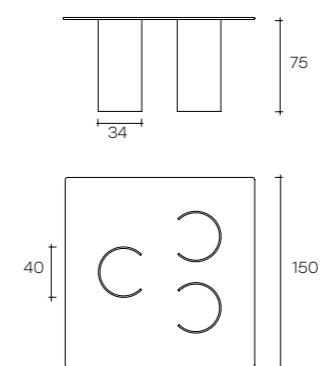

Piano disponibile su misura.  
Top available in custom dimensions.

### Piano in vetro \_ Glass top



Standard  
Standard



Extralight  
Extralight



Fumé  
Smoked



Bronzo  
Bronze

### Base in vetro curvato \_ Curved glass base



Standard  
Standard



Extralight  
Extralight



Fumé  
Smoked



Bronzo  
Bronze



Nero95  
Black95



Tavolo composto da basi in vetro trasparente o vetro extralight curvato da 10 mm e piano in vetro trasparente o extralight da 15 mm temperato. Disponibile anche con piani a misura.

Table consisting of 10 mm-thick curved transparent or extralight glass bases and 15 mm-thick transparent or extralight tempered glass top. Custom size top available on request.

Table composée de bases en verre transparent ou en verre extralight cintré de 10 mm et d'un dessus en verre trempé transparent ou en verre extralight de 15 mm. La table Sahara est également disponible avec de dessus sur mesure.

Tisch mit Untergestell aus gebogenem transparentem Glas oder Extralight-Glas Stärke 10 mm, und gehärtete Glasplatte 15 mm Stärke, transparent oder extralight. Auch mit maßgefertigter Platte erhältlich.

**sahara**  
Bartoli Design



Tavolo ellittico.  
Elliptic table.  
210 x 135 x 75 cm  
82 1/16" x 54" x 29 1/2"



Tavolo ellittico.  
Elliptic table.  
210 x 135 x 75 cm  
82 11/16" x 54" x 29 1/2"

# sahara

Bartoli Design



Tavolo composto da basi in vetro trasparente o vetro extralight curvato da 10 mm e piano in vetro trasparente o extralight da 15 mm temperato. Disponibile anche con piani a misura.

Table consisting of 10 mm-thick curved transparent or extralight glass bases and 15 mm-thick transparent or extralight tempered glass top. Custom size top available on request.

Table composée de bases en verre transparent ou en verre extralight cintré de 10 mm et d'un dessus en verre trempé transparent ou en verre extralight de 15 mm. La table Sahara est également disponible avec de dessus sur mesure.

Tisch mit Untergestell aus gebogenem transparentem Glas oder Extralight-Glas Stärke 10 mm, und gehärtete Glasplatte 15 mm Stärke, transparent oder extralight. Auch mit maßgefertigter Platte erhältlich.

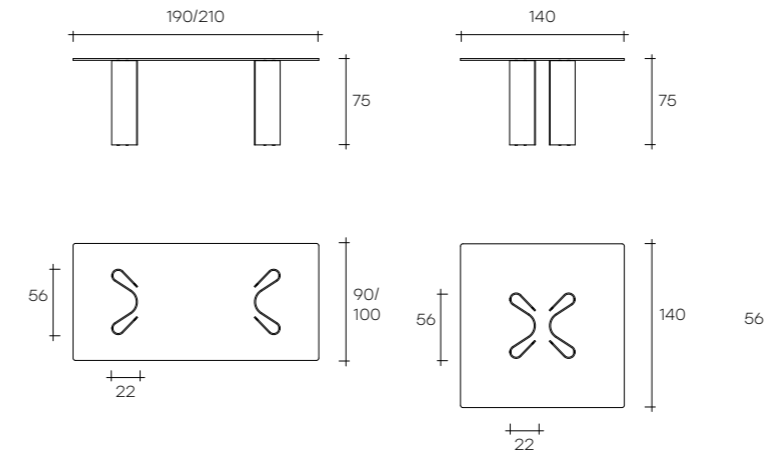

rettangolare / rectangular  
190 x 90 x 75 cm  
74 3/4" x 35 7/16" x 29 1/2"  
210 x 100 x 75 cm  
82 11/16" x 39 3/8" x 29 1/2"

quadrato / square  
140 x 140 x 75 cm  
55 1/8" x 55 1/8" x 29 1/2"

Piano disponibile su misura.  
Top available in custom dimensions.

## Piano in vetro \_ Glass top



Standard  
Standard



Extralight  
Extralight



Fumé  
Smoked



Bronzo  
Bronze

## Base in vetro curvato \_ Curved glass base



Standard  
Standard



Extralight  
Extralight



Fumé  
Smoked



Bronzo  
Bronze

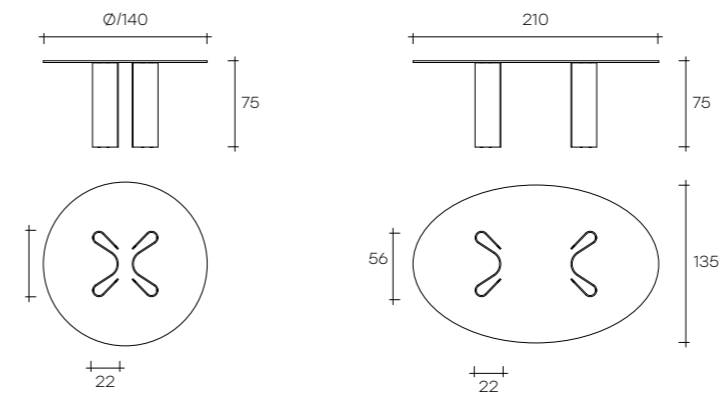

rotondo / round  
Ø140 x 75 cm  
Ø55 1/8" x 29 1/2"

ellittico / elliptic  
210 x 135 x 75 cm  
82 11/16" x 54" x 29 1/2"



Tavolo composto da basi in vetro curvato da 12 mm con lati da 45 cm e piano in vetro da 15 mm temperato.

Table with 12 mm-thick curved glass base (sides 45 cm) and 15 mm-thick tempered glass top.

Table avec piètement en verre cintré de 12 mm, côtés de 45 cm. Plateau en verre trempé de 15 mm.

Tisch mit Untergestell aus 12 mm-starkem gebogenem Glas mit Winkeln von 45 cm. Gehärtete Glasplatte, Stärke 15 mm.



Tavolo rettangolare in vetro bronzo.  
Rectangular table in brozne glass.

300 x 110 x 75 cm  
118 1/8" x 43 5/16" x 29 1/2"

Poltroncine Newton, specchi Shift, libreria Inori.  
Newton chairs, Shift mirrors, Inori bookcase.

# corner

CRS Fiam

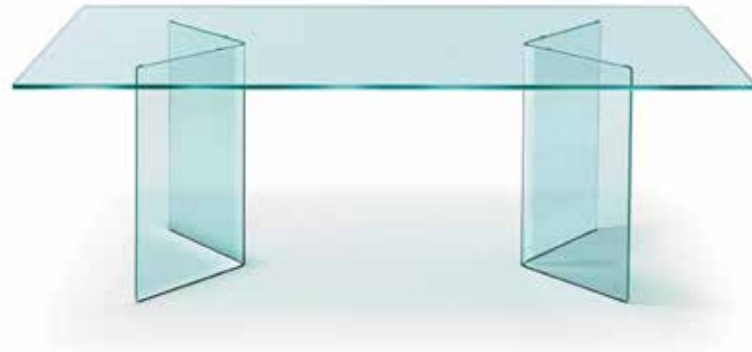

Tavolo composto da basi in vetro curvato da 12 mm con lati da 45 cm e piano in vetro da 15 mm temperato.

Table with 12 mm-thick curved glass base (sides 45 cm) and 15 mm-thick tempered glass top.

Table avec piètement en verre cintré de 12 mm, côtés de 45 cm. Plateau en verre trempé de 15 mm.

Tisch mit Untergestell aus 12 mm-starkem gebogenem Glas mit Winkeln von 45 cm. Gehärtete Glasplatte, Stärke 15 mm.

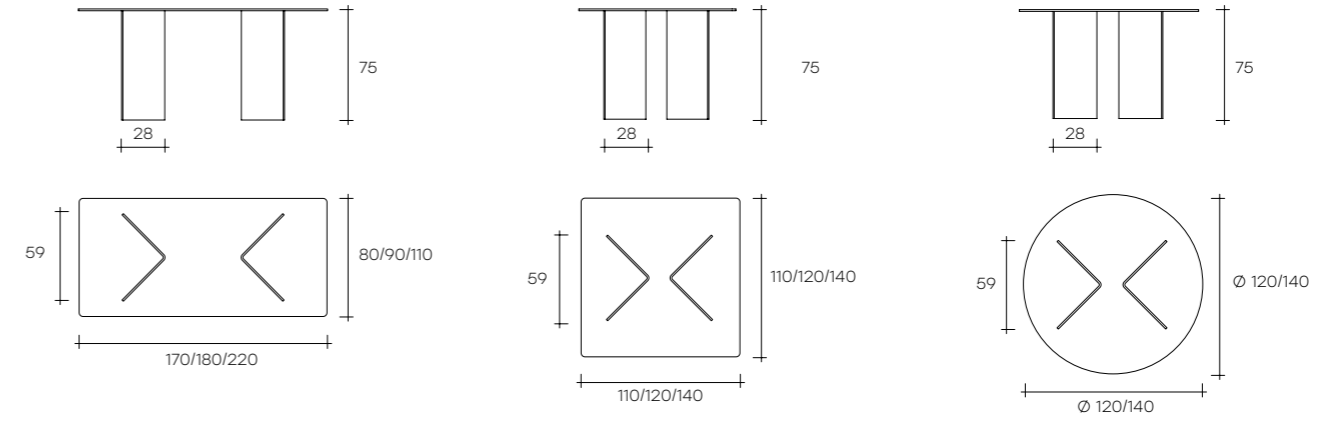

rettangolare / rectangular

170 x 80 x 75 cm  
 66 <sup>15</sup>/<sub>16</sub>" x 31 <sup>1</sup>/<sub>2</sub>" x 29 <sup>1</sup>/<sub>2</sub>"  
 180 x 90 x 75 cm  
 70 <sup>7</sup>/<sub>8</sub>" x 35 <sup>7</sup>/<sub>16</sub>" x 29 <sup>1</sup>/<sub>2</sub>"  
 220 x 110 x 75 cm  
 86 <sup>5</sup>/<sub>8</sub>" x 43 <sup>5</sup>/<sub>16</sub>" x 29 <sup>1</sup>/<sub>2</sub>"

quadrato / square

110 x 110 x 75 cm  
 43 <sup>5</sup>/<sub>16</sub>" x 43 <sup>5</sup>/<sub>16</sub>" x 29 <sup>1</sup>/<sub>2</sub>"  
 120 x 120 x 75 cm  
 47 <sup>1</sup>/<sub>4</sub>" x 47 <sup>1</sup>/<sub>4</sub>" x 29 <sup>1</sup>/<sub>2</sub>"  
 140 x 140 x 75 cm  
 55 <sup>1</sup>/<sub>8</sub>" x 55 <sup>1</sup>/<sub>8</sub>" x 29 <sup>1</sup>/<sub>2</sub>"

tondo / round

Ø 120 x 75 cm  
 47 <sup>1</sup>/<sub>4</sub>" x 29 <sup>1</sup>/<sub>2</sub>"  
 Ø 140 x 75 cm  
 55 <sup>1</sup>/<sub>8</sub>" x 29 <sup>1</sup>/<sub>2</sub>"

Piano disponibile su misura.  
 Top available in custom dimensions.

Piano in vetro \_ Glass top



Standard  
Standard



Extralight  
Extralight



Fumé  
Smoked



Bronzo  
Bronze

Base in vetro curvato \_ Curved glass base



Standard  
Standard



Extralight  
Extralight



Fumé  
Smoked



Bronzo  
Bronze





Tavolo basso composto da base in vetro curvato da 12 mm e piano in vetro da 15 mm scolpito a mano. Parti metalliche in acciaio inox.

Coffee table with 12 mm-thick curved glass base and 15 mm-thick hands sculptured glass top. Hardware in stainless steel.

Table basse avec plateau en verre de 15 mm sculpté à la main. Piètement en verre cintré de 12 mm. Détails métalliques en acier inox.

Couchtisch mit 15 mm-starker handbehauener Glasplatte. Untergestell aus 12 mm-starkem gebogenem Glas. Metallteile aus rostfreiem Stahl.





Tavolino.  
Coffee table.  
125 x 125 x 40 cm  
49 3/16" x 49 3/16" x 15 3/4"

# shell

Danny Lane

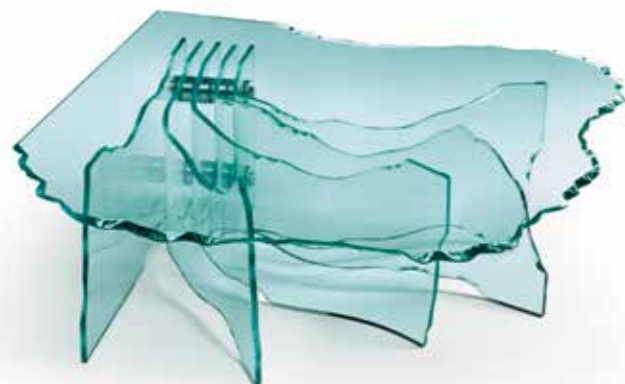

Tavolo basso composto da base in vetro curvato da 12 mm e piano in vetro da 15 mm scolpito a mano. Parti metalliche in acciaio inox.

Coffee table with 12 mm-thick curved glass base and 15 mm-thick hands sculptured glass top. Hardware in stainless steel.

Table basse avec plateau en verre de 15 mm sculpté à la main. Piètement en verre cintré de 12 mm. Détails métalliques en acier inox.

Couchtisch mit 15 mm-starker handbehauener Glasplatte. Untergestell aus 12 mm-starkem gebogenem Glas. Metallteile aus rostfreiem Stahl.

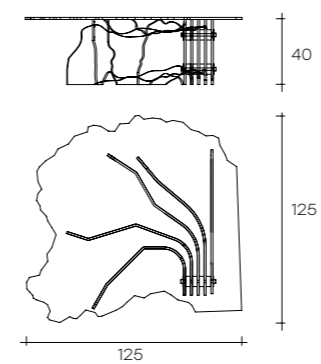

125 x 125 x 40 cm  
49 3/16" x 49 3/16" x 15 3/4"

Base e piano in vetro \_ Glass base and top



Trasparente  
Transparent



Extralight  
Extralight



Tavolo basso in vetro curvato. Disponibile anche su misura.

Coffee table in curved glass. Also available on customized size.

Table basse en verre cintré. Egalement disponible sur mesure.

Couchtisch aus gebogenem Glas. Auch als Maßanfertigung lieferbar.



Tavolino.  
Coffee table.  
160 x 52 x 22 cm  
63" x 20 1/2" x 8 11/16"

# rialto

CRS Fiam

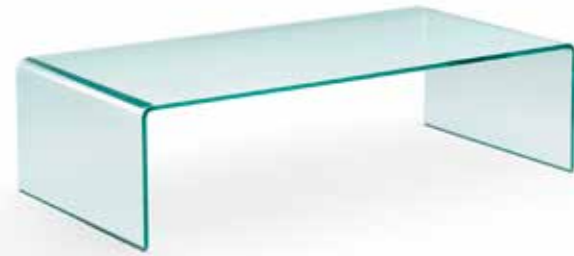

Tavolo basso in vetro curvato. Disponibile anche su misura.

Coffee table in curved glass. Also available on customized size.

Table basse en verre cintré. Egalement disponible sur mesure.

Couchtisch aus gebogenem Glas. Auch als Maßanfertigung lieferbar.

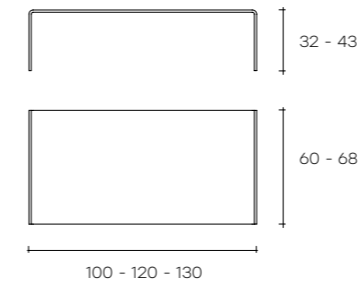

rettangolare / rectangular

100 x 60 x 32 cm  
39 3/8" x 23 5/8" x 12 5/8"

120 x 60 x 32 cm  
47 1/4" x 23 5/8" x 12 5/8"

130 x 68 x 32 cm  
51 3/16" x 26 3/4" x 12 5/8"

120 x 60 x 43 cm  
47 1/4" x 23 5/8" x 16 15/16"

130 x 68 x 43 cm  
51 3/16" x 26 3/4" x 16 15/16"

Tavolino in vetro curvato \_ Curved glass coffee table



Trasparente  
Transparent



Extralight  
Extralight



Fumé  
Smoked



Bronzo  
Bronze



Comodino monolitico in vetro curvato da 10 mm.

Monolithic bedside table in 10 mm-thick curved glass.

Chevet d'une seule dalle de verre cintré de 10 mm.

Nachttisch aus 10 mm-starkem gebogenem Glas,  
aus einer einzigen Glasplatte gefertigt.

**toki**

Setsu & Shinobu Ito





Tavolino / comodino.  
Side table / bedside table.  
52 x 43 x 60 cm  
20 1/2" x 16 15/16" x 23 5/8"



Tavolino / comodino.  
Side table / bedside table.  
52 x 43 x 60 cm  
20 1/2" x 16 15/16" x 23 5/8"

# toki

Setsu & Shinobu Ito



Comodino monolitico in vetro curvato da 10 mm.

Monolithic bedside table in 10 mm-thick curved glass.

Chevet d'une seule dalle de verre cintré de 10 mm.

Nachttisch aus 10 mm-starkem gebogenem Glas,  
aus einer einzigen Glasplatte gefertigt.

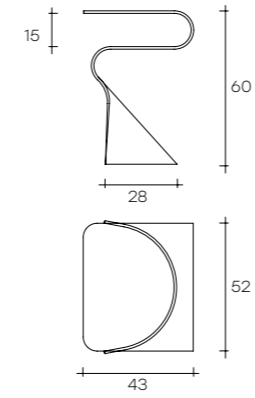

52 x 43 x 60 cm  
20 1/2" x 16 15/16" x 23 5/8"

Base in vetro curvato \_ Curved glass base



Trasparente  
Transparent



Extralight  
Extralight

Consolle in vetro curvato da 12 mm. Disponibile anche con ripiano in vetro da 10 mm e in vetro extralight.

Console in 12 mm-thick curved glass. Also available with 10 mm-thick glass shelf and in extralight glass.

Console en verre cintré de 12 mm. Disponible aussi avec étagère en verre de 10 mm et en verre extralight.

Konsole aus 12 mm-starkem gebogenem Glas. Auch mit Fachboden aus 10 mm-starkem Glas und aus extralight Glas lieferbar.



elementare  
Enrico Tonucci

Consolle con ripiano.  
Console with shelf.  
120 x 36 x 76 cm  
47 1/4" x 14 3/16" x 29 5/16"



# elementare

Enrico Tonucci



Consolle in vetro curvato da 12 mm. Disponibile anche con ripiano in vetro da 10 mm (L 117 cm, P 36 cm).

Console in 12 mm-thick curved glass. Also available with 10 mm-thick glass shelf (L 117 cm, W 36 cm).

Console en verre cintré de 12 mm. Disponible aussi avec étagère en verre de 10 mm (L 117 cm, P 36 cm).

Konsole aus 12 mm-starkem gebogenem Glas. Auch mit Fachboden aus 10 mm-starkem Glas (L 117 cm, B 36 cm) lieferbar.

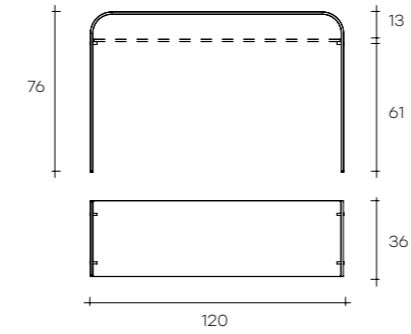

120 x 36 x 76 cm  
47 1/4" x 14 3/16" x 29 5/16"

Base in vetro curvato \_ Curved glass base



Trasparente  
Transparent



Extralight  
Extralight



Consolle in vetro curvato da 15 mm. Disponibile anche con ripiano in vetro curvato acidato da 6 mm.

Console in 15 mm-thick curved glass. Also available with 10 mm-thick acid etched glass shelf.

Console en verre cintré de 15 mm. Disponible aussi avec étagère en verre cintré dépoli de 6 mm.

Konsole aus 15 mm-starkem gebogenem Glas. Auf Wunsch: gebogener Fachboden aus geätztem 6 mm-starkem Glas.

**charlotte**  
Prospero Rasulo



Console.  
Console.  
112 x 36 x 80 cm  
44 1/8" x 14 3/16" x 31"



# charlotte

Prospero Rasulo



Consolle in vetro curvato da 15 mm. Disponibile anche con ripiano in vetro curvato acidato da 6 mm.

Console in 15 mm-thick curved glass. Also available with 10 mm-thick acid etched glass shelf.

Console en verre cintré de 15 mm. Disponible aussi avec étagère en verre cintré dépoli de 6 mm.

Konsole aus 15 mm-starkem gebogenem Glas. Auf Wunsch: gebogener Fachboden aus geätztem 6 mm-starkem Glas.

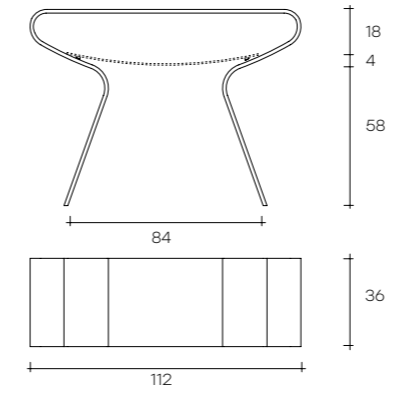

112 x 36 x 80 cm  
44 1/8" x 14 3/16" x 31"

Base in vetro curvato \_ Curved glass base



Trasparente  
Transparent



Extralight  
Extralight



Vetrina elettrificata in vetro curvato da 6 mm con quattro ripiani fissi in vetro da 6 mm (L 58 cm, P 31 cm) e top in vetro da 12 mm. Profili in alluminio finitura brill spazzolato. Anta con serratura. Corpo illuminante (optional) posizionabile anche sotto il top.

Wired showcase in 6 mm-thick curved glass, with four 6 mm-thick glass shelves (L 58 cm, W 31 cm), 12 mm thick glass top, door with lock. Profiles in brushed aluminium glossy finish. The optional lights can also be placed under the top.

Vitrine électrifiée en verre cintré de 6 mm avec quatre étagères fixes en verre de 6 mm, top en verre de 12 mm, porte avec serrure. Profils en aluminium brossé finition brillante. Les projecteurs peuvent être positionnés aussi sous le plateau.

Vitrine aus 6 mm-starkem gebogenem Glas mit vier festen Fachböden aus 6 mm-starkem Glas. Ausgerüstet für eine Beleuchtung. Top aus 12 mm-starkem Glas. Profile aus gebürstetem glänzendem Aluminium Tür mit Schloss. Die Beleuchtung kann auch unter das Top angebracht werden.

**palladio**  
Vittorio Livi



Vetrina in vetro trasparente,  
base in vetro extralight retroargentato.  
Showcase in transparent glass,  
back-silvered extralight glass base.  
64 x 37 x 166 cm  
25 <sup>3</sup>/<sub>16</sub>" x 14 <sup>9</sup>/<sub>16</sub>" x 65 <sup>3</sup>/<sub>8</sub>"



Vetrina in vetro trasparente,  
base in vetro extralight retroargentato.  
Showcase in transparent glass,  
back-silvered extralight glass base.  
64 x 37 x 166 cm  
25 3/16" x 14 9/16" x 65 3/8"

# palladio

Vittorio Livi



Vetrina elettrificata in vetro curvato da 6 mm con quattro ripiani fissi in vetro da 6 mm (L 58 cm, P 31 cm) e top in vetro da 12 mm. Profili in alluminio finitura brill spazzolato. Anta con serratura. Corpo illuminante (optional) posizionabile anche sotto il top.

Wired showcase in 6 mm-thick curved glass, with four 6 mm-thick glass shelves (L 58 cm, W 31 cm), 12 mm thick glass top, door with lock. Profiles in brushed aluminium glossy finish. The optional lights can also be placed under the top.

Vitrine électrifiée en verre cintré de 6 mm avec quatre étagères fixes en verre de 6 mm, top en verre de 12 mm, porte avec serrure. Profils en aluminium brossé finition brillante. Les projecteurs peuvent être positionnés aussi sous le plateau.

Vitrine aus 6 mm-starkem gebogenem Glas mit vier festen Fachböden aus 6 mm-starkem Glas. Ausgerüstet für eine Beleuchtung. Top aus 12 mm-starkem Glas. Profile aus gebürstetem glänzendem Aluminium Tür mit Schloss. Die Beleuchtung kann auch unter das Top angebracht werden.

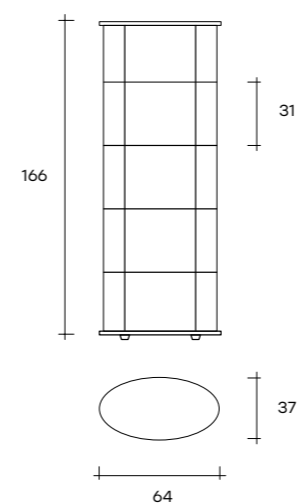

112 x 36 x 80 cm  
44 1/8" x 14 3/16" x 31"

## Struttura in vetro curvato \_ Curved glass structure



Trasparente  
*Transparent*



Extralight  
*Extralight*

## Base in legno \_ Wood base



Noce Canaletto  
*Canaletto Walnut*

## Base in vetro \_ Glass base



Acidato  
retroverniciato Bianco  
*White back-painted  
acid-etched*



Retroverniciato nero  
*Black back-painted*



Sistema composto da elementi in vetro o legno modulari. La modularità e versatilità ne permette l'utilizzo come libreria, espositore, contenitore, porta Tv. Il sistema si sviluppa anche in situazione autoportanti (inori freestanding): nelle versioni in vetro e nella misura larga cm 240, da altezza minima 135 cm sino all'altezza massima 180 cm il sistema prevede delle barre di irrigidimento in alluminio anodizzato nero.

System consisting of modular glass or wood elements. Its modularity and versatility allow it to be used as a bookcase, display case, storage unit or TV unit.

The system can also be used to construct free-standing compositions (inori freestanding): in glass versions and in width 240 cm, from a height of minimum 135 cm up to the maximum height of 180 cm the system is complete with black anodised aluminium reinforcement bars.

System aus modularen Glas-oder Holz-Elementen. Vielseitig einsetzbar und beliebig kombinierbar, als Bücherregal, Ausstellungsregal, TV-Element usw. Auch freistehend als Raumteiler (inori freestanding (aus Glas Breite 240 cm, Höhe mindestens 135 cm, maximal 180 cm, mit Verstärkungen aus Schwarz eloxiertem Aluminium).





Basi e ripiani in noce termotrattato nero,  
montanti in vetro fumè H 42cm.  
Heath-treated black finish walnut base and shelves,  
smoked glass uprights H 42cm.  
Composizione lineare:  
240 x 37,5 x 281 cm (per ogni sistema).  
Linear composition:  
94 1/2" x 14 3/4" x 110 5/8" (each system).









Basi e ripiani in noce canaletto finitura Tabacco,  
montanti in vetro bronzo H 42cm.  
Tobacco finish Canaletto walnut base and shelves,  
bronze glass uprights, H 42cm.  
Composizione lineare:  
240 x 37,5 x 281 cm (per ogni sistema).  
Linear composition:  
94 1/2" x 14 3/4" x 110 5/8" (each system).





Base e ripiani in legno Rovere "Old",  
montanti in vetro extralight, H42 cm.  
"Old Style" oak base and shelves;  
extralight glass uprights, H 42 cm.  
Composizione lineare:  
180 x 37,5 x 189 cm (per ogni sistema).  
Linear composition:  
70 7/8" x 14 3/4" x 74 7/16" (each system).

Il sistema Inori Freestanding si sviluppa in situazioni autoportanti: nelle versioni in vetro e nella misura larga 240 cm, da altezza minima 135 cm sino all'altezza massima 180 cm, il sistema prevede delle barre di irrigidimento in alluminio anodizzato nero.

The system Inori offers free-standing solutions: in glass versions and in width 240 cm, from a height of minimum 135 cm up to the maximum height of 180 cm, the system is complete with black anodised aluminium reinforcement bars.

Le système Inori se présente dans des solutions autoporteuses: dans les versions en verre et dans la largeur de 240 cm, d'une hauteur minimale de 135 cm jusqu'à une hauteur maximale de 180 cm, le système est doté de barres d'armature en aluminium anodisé noir.

Das System Inori entwickelt sich als freistehender Raumteiler: in Glasausführung Breite 240 cm, Höhe mindestens 135 cm, maximal 180 cm, mit Verstärkungen aus Schwarz eloxiertem Aluminium.

# inori freestanding

Setsu & Shinobu Ito





Base in vetro fumè retroverniciato nero,  
ripiani in vetro fumè,  
montanti in vetro trasparente H 32 e 42 cm.

Black back-painted smoked glass bases,  
Smoked glass shelves,  
Transparent glass uprights, H 32 and 42 cm.

240 x 36,5 x 180 cm (con accessorio dedicato).  
94 1/2" x 14 3/8" x 70 7/8" (with reinforcement bars).

# inori

Setsu & Shinobu Ito



Sistema composto da elementi in vetro o legno modulari. La modularità e versatilità ne permette l'utilizzo come libreria, espositore, contenitore porta tv, sviluppabili sia in situazioni con fissaggio a muro che autoportanti. Tutti i montanti sono liberamente posizionabili tramite sistema di ancoraggio e scorrimento a binario applicato su ogni singolo ripiano. Binario in alluminio anodizzato nero.

Modular book shelves glass or wood system. The versatility and assembly possibilities allow the utilization as a show-case, display-case, TV-unit. Available the free-standing version and wall unit. The uprights are freely adjustable on each shelf through sliding rails and fixing device. Slides in anodized black aluminum.

Système composé d'éléments modulables en verre ou en bois. Sa modularité et sa versatilité permettent l'utilisation comme bibliothèque, présentoir, conteneur, portes-TV dans les versions soit appuyantes au sol soit accrochables au mur. Tous les montants sont positionnables avec un système de fixation et rail appliqué sur chaque étagère. Rail en aluminium anodisé noir.

System aus modularen Glas-oder Holz-Elementen. Vielseitig einsetzbar und beliebig kombinierbar, als Bücherregal, Ausstellungsregal, TV-Element usw. Verschiedene Kombinationen sind möglich, als freistehende Ausführung bzw. als Wandregal. Die Stützen sind frei verstellbar auf jedem Fachboden durch Führung und Befestigungsmodul. Laufschiene aus schwarzem eloxiertem Aluminium.

## Basi / Bases

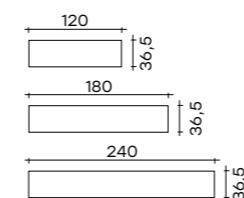

## Montanti / Uprights

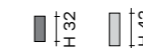

## Ripiani / Shelves

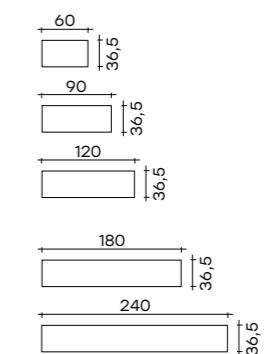

Disponibili solo nelle finiture vetro  
In glass versions only  
Pour les étagères en verre uniquement  
Für die Glasfachböden nur

Disponibili in tutte le finiture  
In all finishings  
Pour toutes finitions  
Für alle Finish

## Basi e ripiani in legno \_ Wood bases and shelves



Rovere "Old"  
"Old Style" oak



Noce canaletto  
finitura tabacco  
Canaletto walnut  
tobacco finish



Noce termotrattato  
nero  
Heath-treated black  
finish walnut

## Base in vetro \_ Glass base



Extralight  
retroverniciato  
bianco  
Extralight white  
back-painted glass



Fumé  
retroverniciato nero  
Smoked glass  
black back-stained

## Ripiani in vetro \_ Glass shelves



Standard  
Standard



Extralight  
Extralight



Fumé  
Smoked

## Montante in vetro curvato \_ Curved glass upright



Standard  
Standard



Extralight  
Extralight



Fumé  
Smoked



Bronzo  
Bronze



Nero95  
Black95



Tutti i montanti sono liberamente posizionabili tramite sistema di ancoraggio e scorrimento a binario applicato su ogni singolo ripiano. Binario in alluminio anodizzato nero.

The uprights are freely adjustable on each shelf through sliding rails and fixing device. Slides in anodized black aluminum.

Tous montants sont positionnables avec un système de fixation et rail appliqué sur chaque étagère. Rail en aluminium anodisé noir.

Die Stützen sind frei verstellbar auf jedem Fachboden durch Führung und Befestigungsmodul. Laufschiene aus schwarzem eloxiertem Aluminium.



Alcuni suggerimenti tra le infinite soluzioni \_ Just a few of the numerous solutions  
 Quelques suggestions parmi de nombreuses possibilités \_ Einige Vorschläge zu unzähligen Lösungen

### Libreria \_ Bookcase \_ Bibliothèque \_ Bücherregal

Montanti / Uprights  
 Montants / Stütze

H 32 H 42

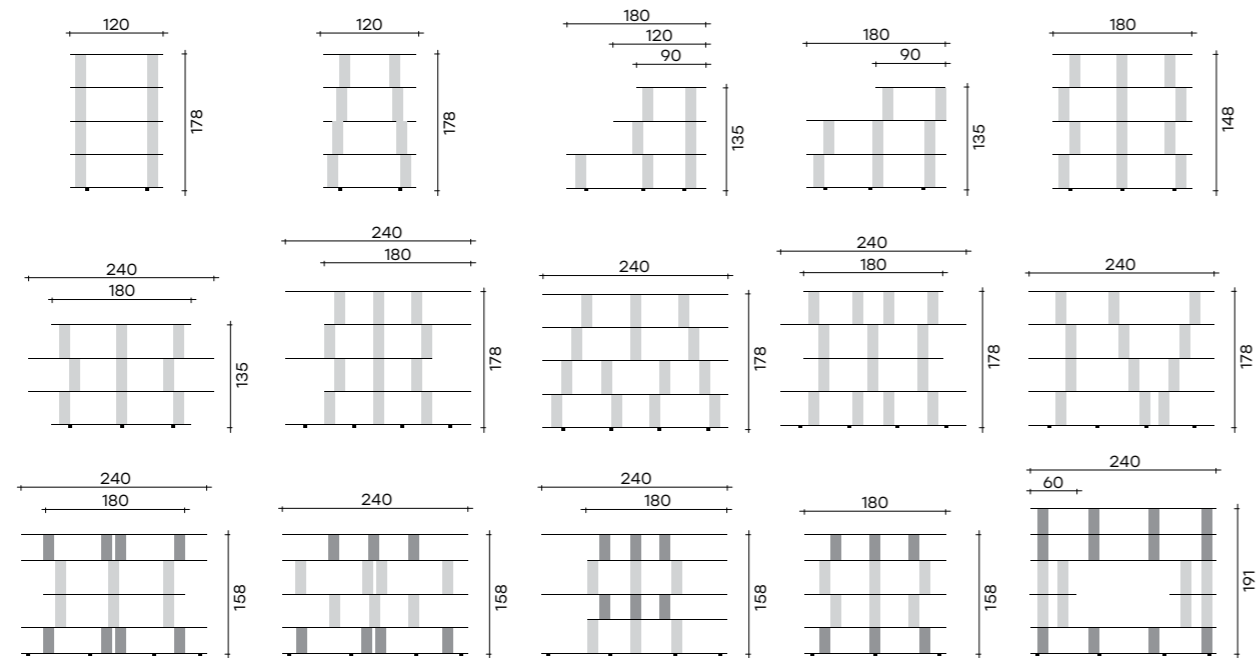

### Porta TV \_ Tv unit \_ Porte-TV \_ TV-Ständer

Montanti / Uprights  
 Montants / Stütze

H 32 H 42

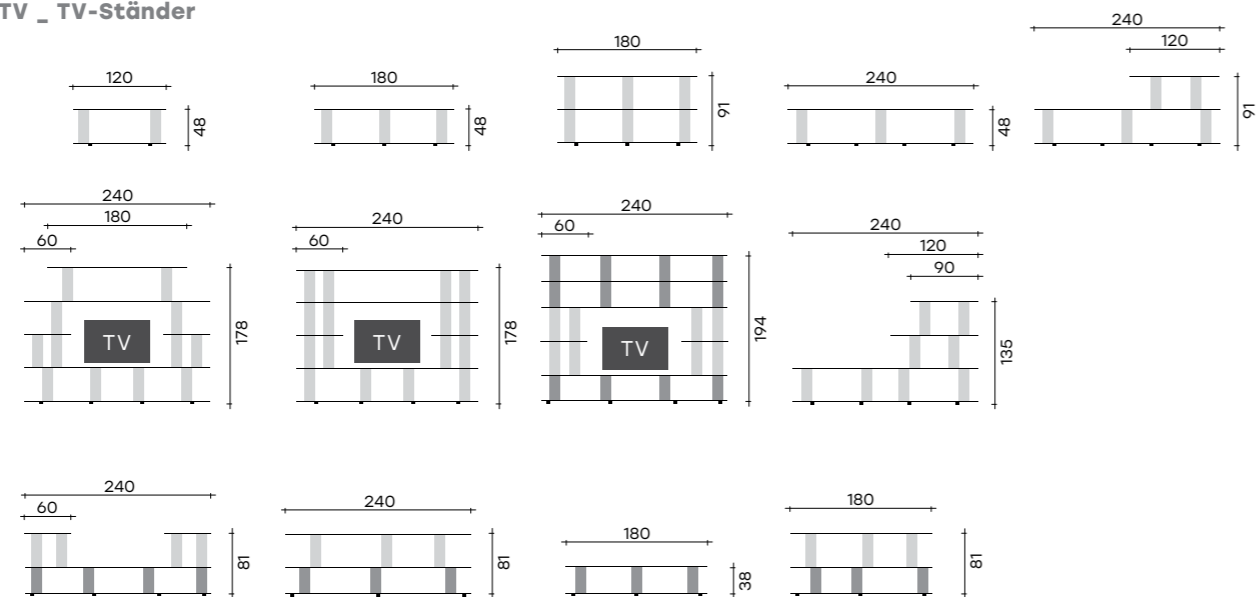

### Console \_ Console \_ Console \_ Konsole

Montanti / Uprights  
 Montants / Stütze

H 42

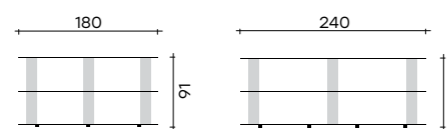

### Retro divano \_ Sofa back sideboard \_ Bout de Canape \_ Sofa Hinterelement

Montanti / Uprights  
 Montants / Stütze

H 32 H 42

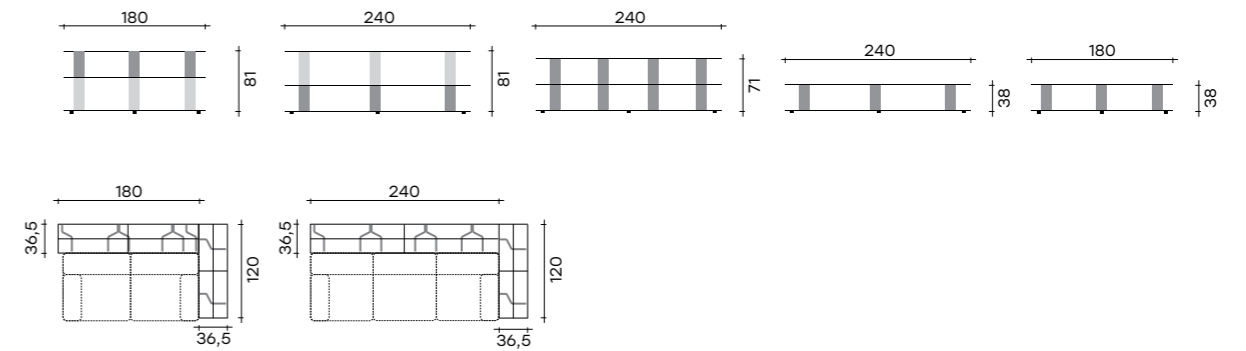

### Mobile basso \_ Low unit \_ Meubles bas \_ Kleinmöbel

Montanti / Uprights  
 Montants / Stütze

H 32 H 42

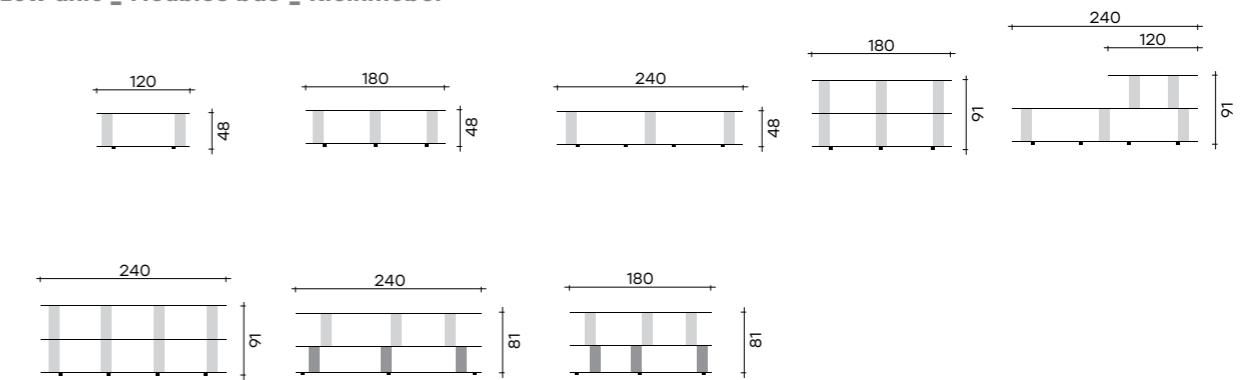

### Soluzione centrostanza \_ Room centrepiece solution \_ Solution en séparation de pièces \_ Zimmermitte-Lösung

Montanti / Uprights  
 Montants / Stütze

H 32 H 42

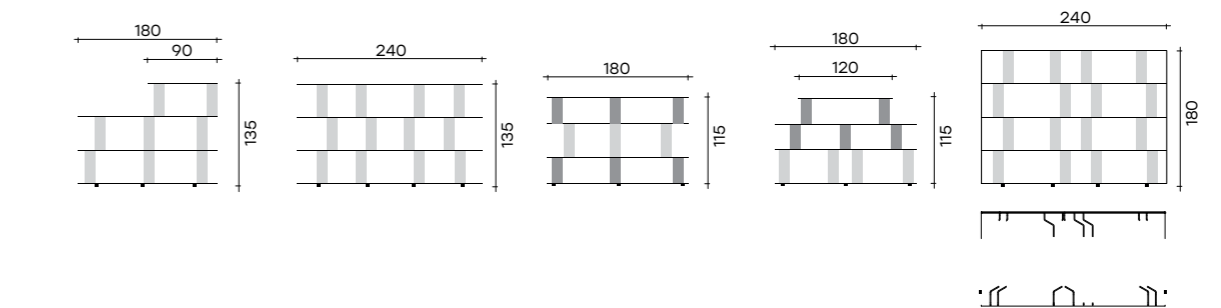

#### Altezza massima per le strutture autoportanti:

- Su basi di lunghezza 120 cm: h max 48 cm (vetro) o 51 cm (legno).
- Su basi di lunghezza 180 cm: h max 135 cm (vetro) o 143 cm (legno).
- Su basi di lunghezza 240 cm: h max 178 cm (vetro) o 189 cm (legno) con accessorio dedicato.

#### Altezza massima per le strutture con ancoraggio a muro:

- Massimo 5 ripiani in vetro, 6 ripiani in legno, base esclusa.

**Distanza massima tra i montanti: 130 cm.**

#### Max. height of the free-standing version:

- With base length 120 cm: h max 48 cm (glass) or 51 cm (wood).
- With base length 180 cm: h max 135 cm (glass) or 143 cm (wood).
- With base length 240 cm: h max 178 cm (glass) or 189 cm (wood) with accessories.

#### Max. height of the wall version:

- Max 5 glass shelves, max 6 wood shelves, base excluded.

**Max. distance between the uprights: 130 cm.**

#### Hauteur maxi. pour les structures posées au sol:

- Avec base de longueur 120 cm: h max 48 cm (verre) ou 51 cm (bois).
- Avec base de longueur 180 cm: h max 135 cm (verre) ou 143 cm (bois).
- Avec base de longueur 240 cm: h max 178 cm (verre) ou 189 cm (bois) avec accessoires.

#### Hauteur maxi. pour les structures accrochables au mur:

- Avec max 5 étagères en verre, max 6 étagères en bois, base excluse.

**Distance maxi entre les montants: 130 cm.**

#### Max. Höhe der Standausführung:

- Mit Basislänge 120 cm: h max 48 cm (Glas) or 51 cm (Holz).
- Mit Basislänge 180 cm: h max 135 cm (Glas) or 143 cm (Holz).
- Mit Basislänge 240 cm: h max 178 cm (Glas) or 189 cm (Holz) mit Accessoires.

#### Max.Höhe der Wandausführung:

- Mit max 5 Glasfachböden, max 6 Holzfachböden, ohne die Basis.

**Max. Abstand zwischen den Stützen: 130 cm.**



**art direction**  
adele martelli

**photo art direction**  
adele martelli  
acanto comunicazione  
(carlo piazzesi)

**rendering images**  
acanto comunicazione

**photography and postproduction**  
studio amatibacciardi  
studio leon

**styling**  
monti studio  
candida zanelli and serenella parri  
conti | marchetti studio

**marketing project**  
daniele livi

**coordination and logistics**  
lorenzo marzoli

**selections**  
olimpia visual plan

september 2024

**credits**

AMINI CARPETS  
AYTM  
COEEDESIGN  
COKI  
EDIZIONI DESIGN  
ENRYHANDS  
FIAMMETTA V.  
FIANDRE ARCHITECTURAL SURFACES / IRIS CERAMICA  
FLOU  
FOSCARINI  
GOLRAN  
GUAXS  
IL LOFT  
INDIKON - CARPET EDITION  
LISTONE GIORDANO  
MARINO CRISTAL  
MM LAMPADARI  
NASONMORETTI  
NOCTIS  
OPIFICIO SERICO FIORENTINO  
PANZERI ILLUMINAZIONE  
SALVATORI  
SALVIATI  
SERGIO COLLEONI  
SIRECOM TAPPETI  
SKLO STUDIO  
VIBIEFFE 85  
ZENO FINOTTI

**Fiam Italia**  
Via Ancona 1/b  
61010 Tavullia (PU)  
Italy

T: +39 0721 20051  
F: +39 0721 202432

fiamitalia.it  
info@fiamitalia.it

#fiamitalia

follow us on

